

ADVANTAGES OF COVERS/HOODS CAPOTEX

CAPOTEX	OTHER MANUFACTURERS
	
RIGIDITY FOLD GREATER RIGIDITY OF THE COVER / HOOD AVOID CUTS DURING ITS MANIPULATION	
	
ROUNDED CORNER AVOID CUTS DURING ITS MANIPULATION	

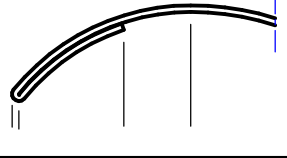

Sheet thickness 0.6mm and 1.2mm. in edges.

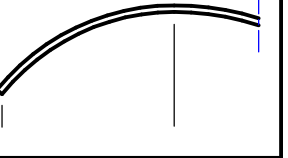
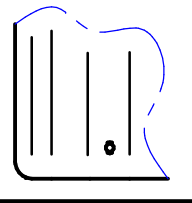
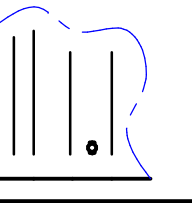
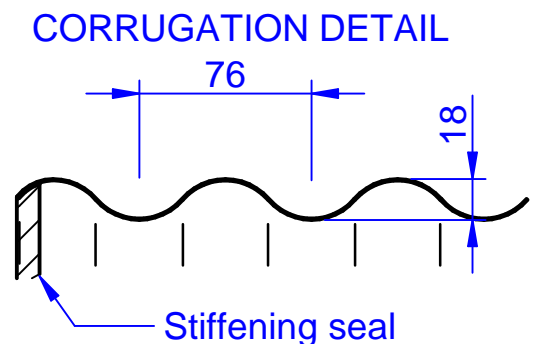
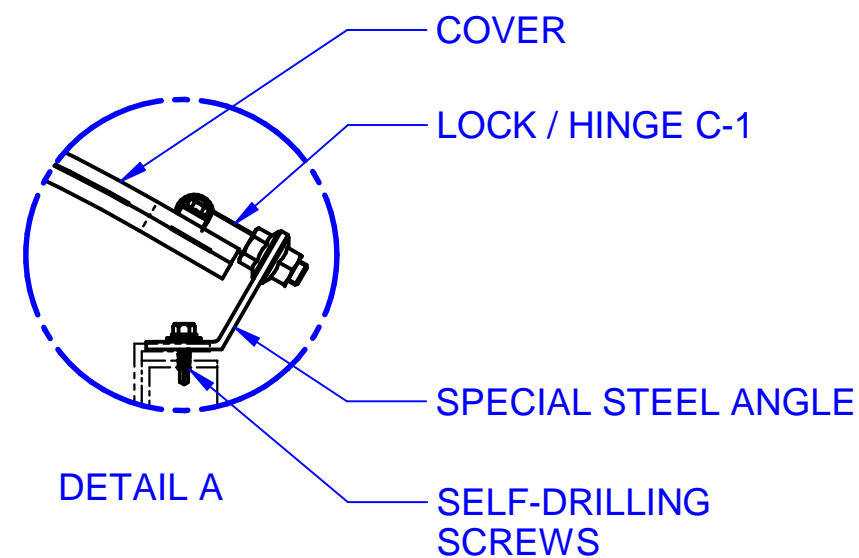
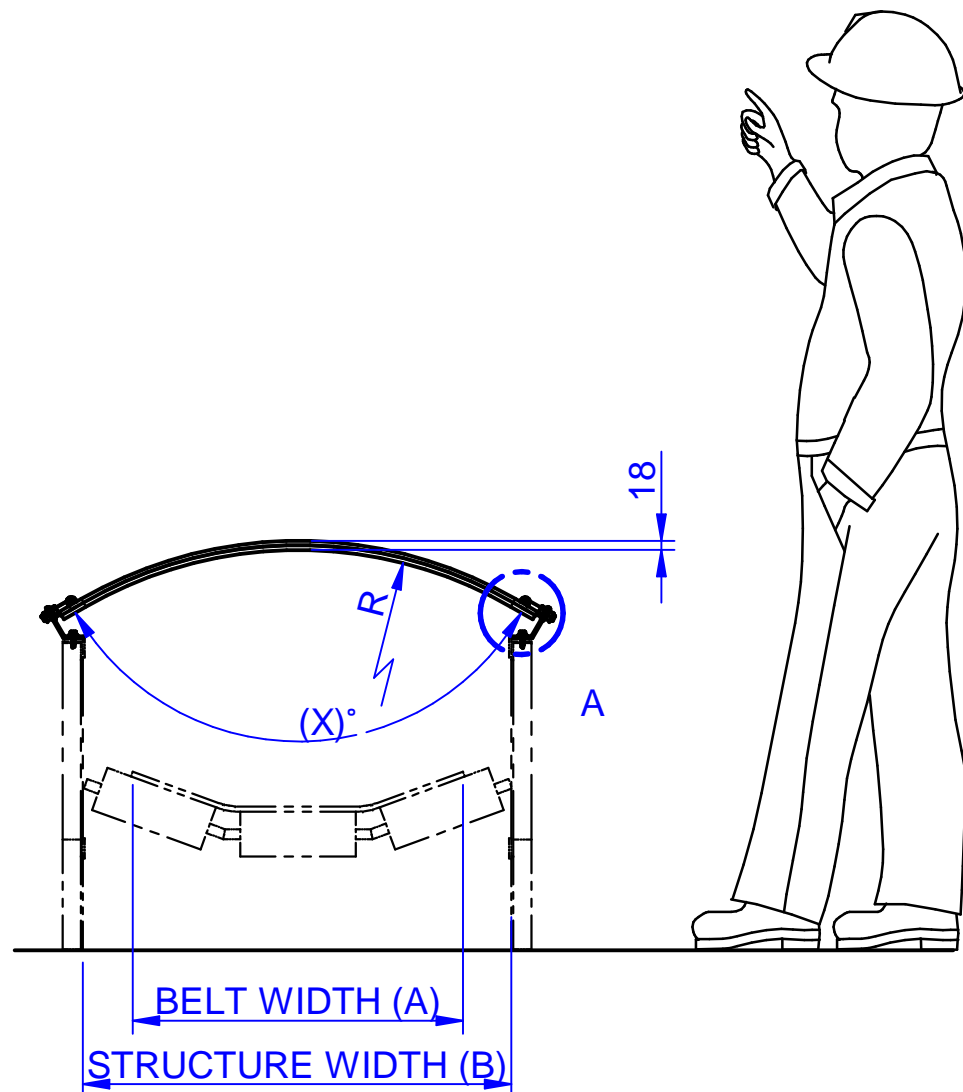
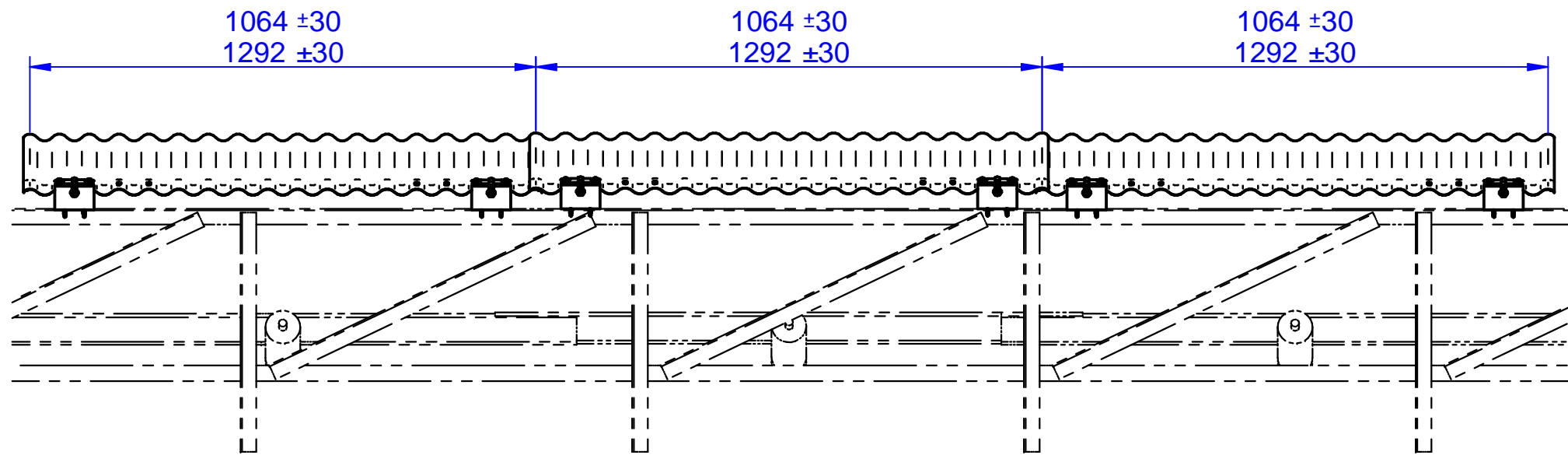
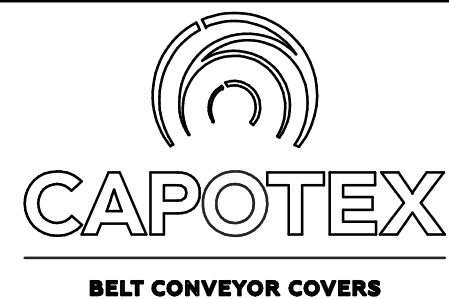

NOT SPECIFIED TOLERANCE

DIMENSIONS		ANGLES	
()	: ±2.00	0°	: ±02' 00"
X.	: ±0.50	0° 0'	: ±00' 30"
X.0	: ±0.25	0° 0' 0"	: ±00' 03"
X.00	: ±0.08		
X.000	: ±0.02		

CAD DRAWING. HANDLING ON CAD SYSTEM ONLY

THIS DRAWING IS OWNED BY **CAPOTEX**.
COPY OR REPRODUCTION IS FORBIDDEN
WITHOUT PREVIOUS NOTICE

SCALE	DESIGNED	DRAWN	CHECKED	SHEET 1 OF 2	FORMAT
-	P.GLEZ		J.SAURA	EUR	A3

NAME
**CAPOARC COVER
(GENERAL VIEW)**

DRAWING NUMBER
CAD FILE
CAPOTAJE CAPOARC_01 (Ingles).dft

INSTALLATION EXAMPLE

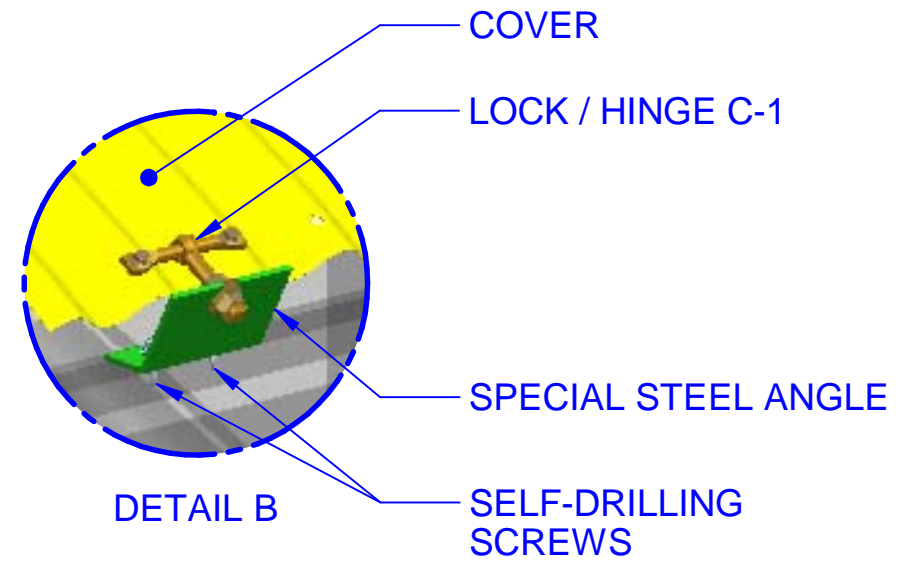
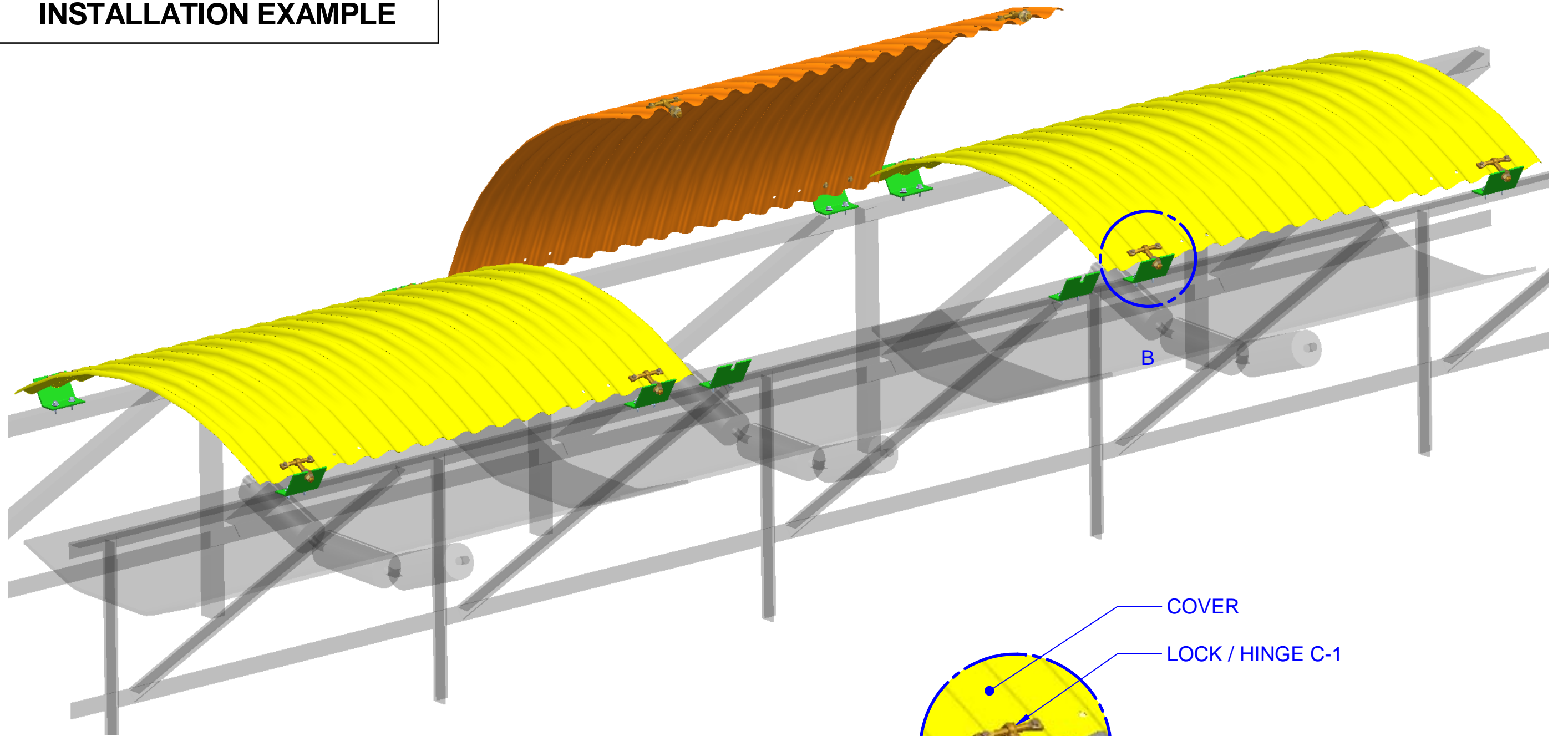

	NOT SPECIFIED TOLERANCE		CAD DRAWING. HANDLING ON CAD SYSTEM ONLY THIS DRAWING IS OWNED BY CAPOTEX . COPY OR REPRODUCTION IS FORBIDDEN WITHOUT PREVIOUS NOTICE	SCALE	DESIGNED	DRAWN	CHECKED	SHEET 2 OF 2	FORMAT
	DIMENSIONS	ANGLES		-	P.GLEZ	J.SAURA	OCT-10	EUR	A3
	() : ±2.00 X. : ±0.50 X.0 : ±0.25 X.00 : ±0.08 X.000 : ±0.02	0° : ±02' 00" 0° 0' : ±00' 30" 0° 0' 0" : ±00' 03"		NAME	CAPOARC COVER (GENERAL VIEW)		DRAWING NUMBER		
						CAPOTAJE CAPOARC_01 (Ingles).dft			